

**SARDINIAN
OPEN 2021**

Maschio Bianca

Adult- PIUMA LEGGERO

64,00
kg

5 min

1 Fighters

GI

	calls	1	2	3	dq	doc	peso
1	Filippo Costanzi - Milano Jiu Jitsu - l'Accademia						

	calls	1	2	3	dq	doc	peso
2							

	calls	1	2	3	dq	doc	peso
3							

	calls	1	2	3	dq	doc	peso
4							

	calls	1	2	3	dq	doc	peso
5							

	calls	1	2	3	dq	doc	peso
6							

	calls	1	2	3	dq	doc	peso
7							

	calls	1	2	3	dq	doc	peso
8							

MBA-PIUMA LEGGERO

1 di 1



1°

2°

3°

3°

ora inizio bracket

nome coordinatore

	calls	1	2	3	dq	doc	peso
9							

	calls	1	2	3	dq	doc	peso
10							

	calls	1	2	3	dq	doc	peso
11							

	calls	1	2	3	dq	doc	peso
12							

	calls	1	2	3	dq	doc	peso
13							

	calls	1	2	3	dq	doc	peso
14							

	calls	1	2	3	dq	doc	peso
15							

	calls	1	2	3	dq	doc	peso
16							

**SARDINIAN
OPEN 2021**

Maschio Bianca Adult-

LEGGERO

76,00
kg

5 min

5 Fighters

GI

	calls	1	2	3	dq	doc	peso
1	Anass Kamal Idrissi - Fn Fight.co Europa						
2							
3							
4	Michele Pitzalis - Mill Hill BJJ						
5							
6							
7							
8	Valerio Giordo - Matside Jiu Jitsu						

MBA-LEGGERO

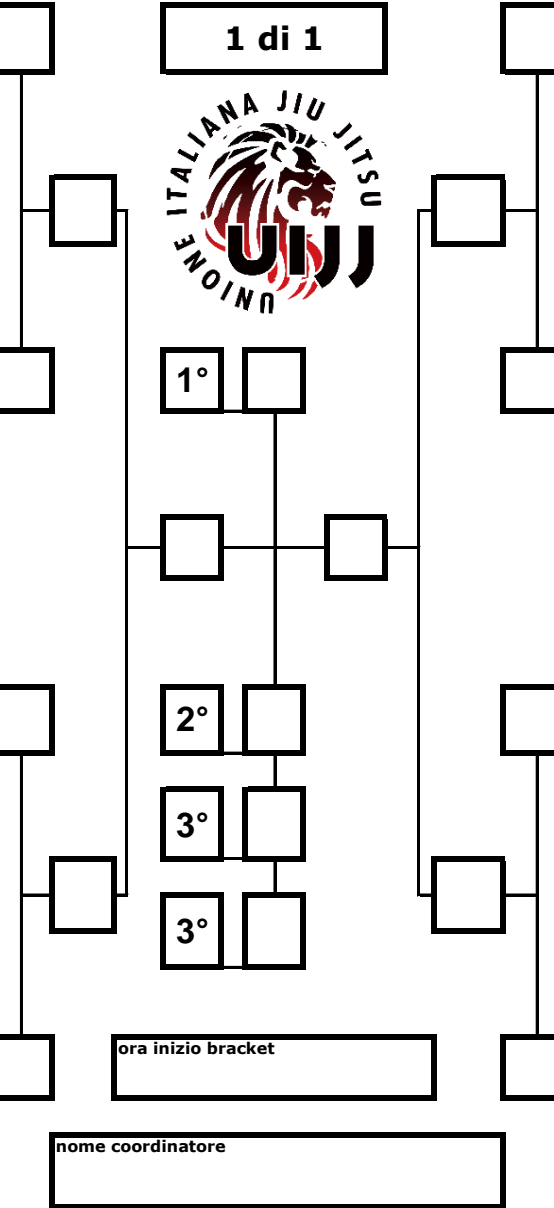

	calls	1	2	3	dq	doc	peso
9	Daniele Barbieri - Fn Fight.co Europa						
10							
11							
12							
13							
14							
15							
16	Gabriele Pagano - Matside Jiu Jitsu						

**SARDINIAN
OPEN 2021**

Maschio

Bianca

Adult-

MEDIO

82,3
kg

5 min

4 Fighters

GI

calls 1 2 3 dq doc peso

1 Giuseppe Curreli - Aeterna Jiu Jitsu

calls 1 2 3 dq doc peso

2

calls 1 2 3 dq doc peso

3

calls 1 2 3 dq doc peso

4

calls 1 2 3 dq doc peso

5

calls 1 2 3 dq doc peso

6

calls 1 2 3 dq doc peso

7

calls 1 2 3 dq doc peso

8 Alessandro Zambon - Milano Jiu Jitsu -
l'Accademia

MBA-MEDIO

1 di 1



1°

2°

3°

3°

ora inizio bracket

nome coordinatore

calls 1 2 3 dq doc peso

9 Lorenzo Abis - Flow

calls 1 2 3 dq doc peso

10

calls 1 2 3 dq doc peso

11

calls 1 2 3 dq doc peso

12

calls 1 2 3 dq doc peso

13

calls 1 2 3 dq doc peso

14

calls 1 2 3 dq doc peso

15

calls 1 2 3 dq doc peso

16 Francesco Carboni - Mill Hill BJJ

**SARDINIAN
OPEN 2021**

Maschio Bianca

Master1 PIUMA LEGGERO

64,00
kg

5 min

3 Fighters

GI

	calls	1	2	3	dq	doc	peso
1	Paolo Langiu - ACCADEMIA GHERRADORES JIU JITSU OSCHIRI						

	calls	1	2	3	dq	doc	peso
2							

	calls	1	2	3	dq	doc	peso
3							

	calls	1	2	3	dq	doc	peso
4							

	calls	1	2	3	dq	doc	peso
5							

	calls	1	2	3	dq	doc	peso
6							

	calls	1	2	3	dq	doc	peso
7							

	calls	1	2	3	dq	doc	peso
8	Luigi Fanton - Officine Jiu Jitsu						

MBM1-PIUMA LEGGERO

1 di 1



1°

2°

3°

3°

ora inizio bracket

nome coordinatore

	calls	1	2	3	dq	doc	peso
	Valerio Galiffa - Aeterna Jiu Jitsu						
9							

	calls	1	2	3	dq	doc	peso
10							

	calls	1	2	3	dq	doc	peso
11							

	calls	1	2	3	dq	doc	peso
12							

	calls	1	2	3	dq	doc	peso
13							

	calls	1	2	3	dq	doc	peso
14							

	calls	1	2	3	dq	doc	peso
15							

	calls	1	2	3	dq	doc	peso
16							

**SARDINIAN
OPEN 2021**

Maschio Bianca

Master1

PIUMA

70,00
kg

5 min

2 Fighters

GI

	calls	1	2	3	dq	doc	peso
1	Gian Luigi Bonino - ACCADEMIA GHERRADORES JIU JITSU OSCHIRI						
2							
3							
4							
5							
6							
7							
8							

MBM1-PIUMA

1 di 1



1°

2°

3°

3°

ora inizio bracket

nome coordinatore

	calls	1	2	3	dq	doc	peso
9	Marco Scodinu - Mill Hill BJJ						
10							
11							
12							
13							
14							
15							
16							

**SARDINIAN
OPEN 2021**

Maschio

Bianca

Master1

MEDIO

82,3
kg

5 min

1 Fighters

GI

	calls	1	2	3	dq	doc	peso
1	Davide Gallo - Budo Clan						

	calls	1	2	3	dq	doc	peso
2							

	calls	1	2	3	dq	doc	peso
3							

	calls	1	2	3	dq	doc	peso
4							

	calls	1	2	3	dq	doc	peso
5							

	calls	1	2	3	dq	doc	peso
6							

	calls	1	2	3	dq	doc	peso
7							

	calls	1	2	3	dq	doc	peso
8							

MBM1-MEDIO

1 di 1



1°

2°

3°

3°

ora inizio bracket

nome coordinatore

	calls	1	2	3	dq	doc	peso
9							

	calls	1	2	3	dq	doc	peso
10							

	calls	1	2	3	dq	doc	peso
11							

	calls	1	2	3	dq	doc	peso
12							

	calls	1	2	3	dq	doc	peso
13							

	calls	1	2	3	dq	doc	peso
14							

	calls	1	2	3	dq	doc	peso
15							

	calls	1	2	3	dq	doc	peso
16							

**SARDINIAN
OPEN 2021**

Maschio

Bianca

Master1

MASSIMI

94,30
kg

5 min

1 Fighters

GI

	calls	1	2	3	dq	doc	peso
1	Davide Atzori - ACCADEMIA GHERRADORES JIU JITSU OSCHIRI						

	calls	1	2	3	dq	doc	peso
2							

	calls	1	2	3	dq	doc	peso
3							

	calls	1	2	3	dq	doc	peso
4							

	calls	1	2	3	dq	doc	peso
5							

	calls	1	2	3	dq	doc	peso
6							

	calls	1	2	3	dq	doc	peso
7							

	calls	1	2	3	dq	doc	peso
8							

MBM1-MASSIMI

	calls	1	2	3	dq	doc	peso

	calls	1	2	3	dq	doc	peso

	calls	1	2	3	dq	doc	peso

	calls	1	2	3	dq	doc	peso

	calls	1	2	3	dq	doc	peso

	calls	1	2	3	dq	doc	peso

	calls	1	2	3	dq	doc	peso

	calls	1	2	3	dq	doc	peso

1 di 1



1°

2°

3°

3°

ora inizio bracket

nome coordinatore

9

10

11

12

13

14

15

16

**SARDINIAN
OPEN 2021**

Maschio

Bianca

Master2

PIUMA LEGGERO

64,00
kg

5 min

1 Fighters

GI

	calls	1	2	3	dq	doc	peso
1	Gabriel Lopez - Sparta Fight Team / Team Carvalho						
2							
3							
4							
5							
6							
7							
8							

MBM2-PIUMA LEGGERO

1 di 1



1°

2°

3°

3°

ora inizio bracket

nome coordinatore

	calls	1	2	3	dq	doc	peso
9							
10							
11							
12							
13							
14							
15							
16							

**SARDINIAN
OPEN 2021**

Maschio Bianca

Master2

LEGGERO

76,00
kg

5 min

1 Fighters

GI

	calls	1	2	3	dq	doc	peso
1	Gabriele Piras - Matside Jiu Jitsu						
2							
3							
4							
5							
6							
7							
8							

MBM2-LEGGERO

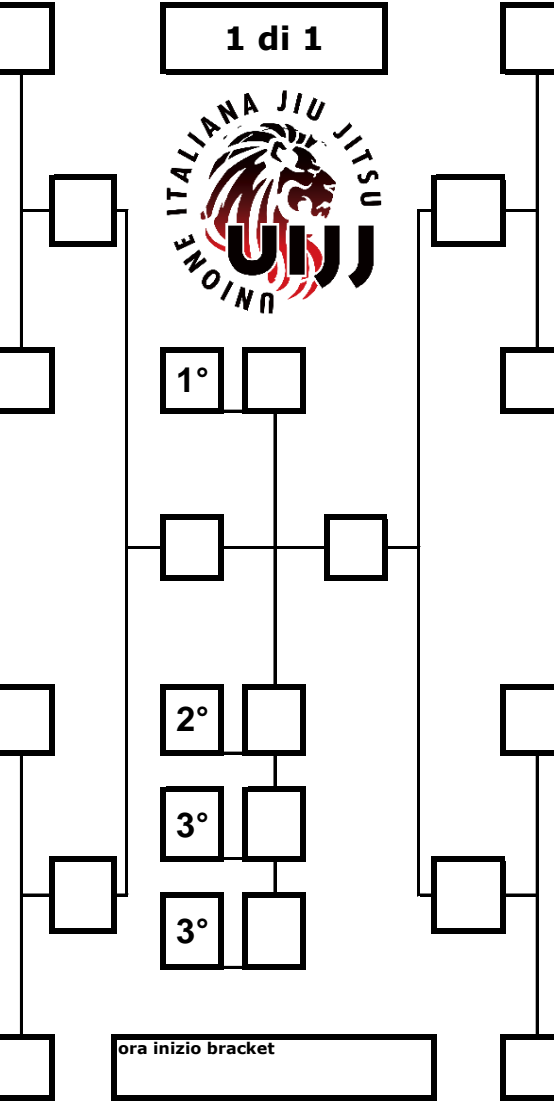

	calls	1	2	3	dq	doc	peso
9							
10							
11							
12							
13							
14							
15							
16							

**SARDINIAN
OPEN 2021**

Maschio Bianca

Master3

SUPER MASSIMI

100,5
kg

5 min

1 Fighters

GI

	calls	1	2	3	dq	doc	peso
1	Alessandro Pintadu - ACCADEMIA GHERRADORES JIU JITSU OSCHIRI						
2							
3							
4							
5							
6							
7							
8							

MBM3-SUPER MASSIMI

1 di 1



1°

2°

3°

3°

ora inizio bracket

nome coordinatore

	calls	1	2	3	dq	doc	peso
9							
10							
11							
12							
13							
14							
15							
16							